

InTouch16™ iPad® / Chromebook® / Laptop Cabinet

55431

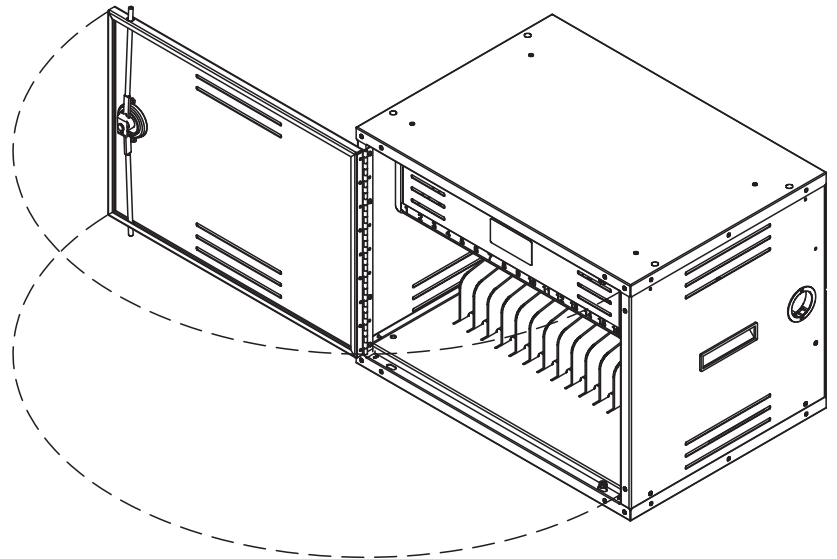
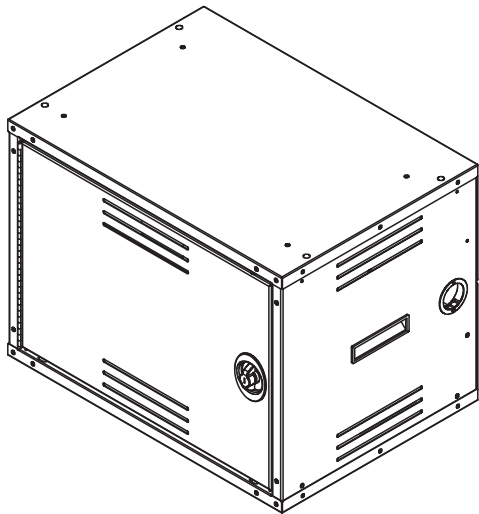

⚠ Important ⚠

Before using this product:

- Read this manual
- Comply with all safety and operating instructions
- Ensure all parts and correct quantities are included

Any parts damaged during shipment must be reported within 15 days of receipt. To report information regarding missing parts or damage, to purchase parts or accessories, or if you have any questions, please contact us.

Thank you for purchasing Spectrum products!

Spectrum Industries, Inc
925 First Avenue, Chippewa Falls, WI 54729 USA
800 235 1262
715 723 6750
www.spectrumfurniture.com



Important Safety and Care Instructions



- Read this owner's manual before assembly or operation.
- Do not allow children to operate.
- For indoor use only. Do not install or store where it will be exposed to moisture.
- Do not block the ventilation openings.
- Do not allow anyone to sit, stand, or climb on the unit.
- Use a damp, soft-cloth, or sponge, with mild soap or detergent solution to clean dirty surfaces. Do not use harsh solvents or abrasives.
- This unit is intended for institutional use. It does not have any user-serviceable parts or user-maintenance requirements. If servicing is necessary, please contact Spectrum Industries for assistance.

Warning - Relocating audio and/or video equipment to furniture not specifically designed to support audio and/or video equipment may result in death or serious injury due to the furnishing collapsing or over turning onto a child.

Warning - Death or serious injury may occur when children climb on audio and/or video equipment furniture. A remote control or toys placed on the furnishing may encourage a child to climb on the furnishing and as a result the furnishing may tip over on to the child.

Electrical Safety:

- Keep the power switches in the OFF position before plugging or unplugging from the wall outlet.
- Turn OFF the devices before plugging them in.
- Ensure total device / equipment load does not exceed 12-amps.
- Do not plug the power cord into an extension cord.
- Inspect the power cords for damage before each use. Do not use power cords that are damaged.
- Unplug power cord from electrical outlet by gripping the cord. Do not unplug the power cord by pulling only on the cord.
- Do not step on, drive over, drag, or place objects on the power cord.
- For added safety, plug the cart into a grounded outlet controlled by a GFI (Ground Fault Interrupter) circuit breaker.
- Damaged electrical components can create significant hazards to users and is not covered by the warranty. Repairs should always be performed by a qualified electrician.
- Electrical devices are not toys. Children are often unaware of the hazards associated with electrical devices. This unit must always be used by adults or with adult supervision.

Hardware Package Contents



(4) 052309
2" x 6" Velcro® Hook
(4) 052310
2" x 6" Velcro® Loop



(4) 044555
3/8" hole plug

Anchoring unit to worksurface or floor

1. The laptop cabinet needs to be permanently and securely attached to a desk or floor to prevent tipping and for security.
2. Set the cabinet into position. Using the mounting holes located on the bottom of the unit as a template, locate and mark the mounting hole locations on the floor / worksurface.
3. For worksurfaces, mark and drill pilot holes at the marked locations. (Fasteners are not provided for floor anchoring due to the large variety of flooring and worksurface materials.)
4. Attach the cabinet to the worksurface or floor with appropriate fasteners. Be sure worksurface is stable and sturdy enough to fully support the unit.

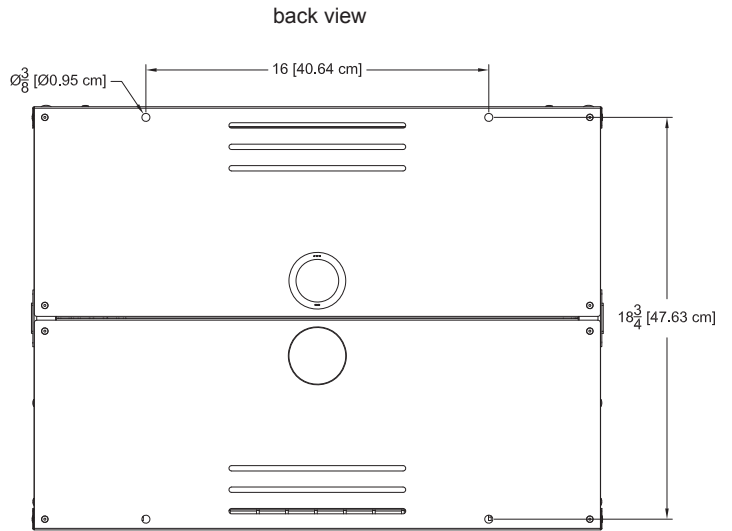

Figure 1

Stacking multiple units (optional)

1. Multiple units can be stacked **no more than 3 high** if necessary, but for stability reasons, stacking requires all units be attached together and anchored to a permanent surface such as the floor and wall (with at least 2 screws).
2. Stack one unit on top of another in its final location. Note: Fasteners to attach units together are not included.
Suggested fasteners: (4) 1/4-20 x 5/8" PHM screws and (4) locknuts.
3. Tighten fasteners securely. **Figure 2.**
4. Repeat this process for the 3rd (top) unit.
5. Anchor the top unit to the wall using appropriate fasteners.

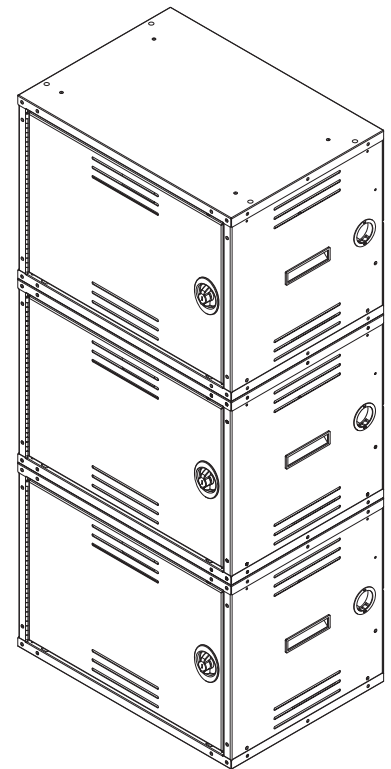

Figure 2



WARNING

THE INTOUCH 16 CABINET CAN BE STACKED ON A STABLE SURFACE (UP TO 3 HIGH). THE INTOUCH 16 CABINET IS NOT INTENDED OR DESIGNED TO BE INDIVIDUALLY HUNG ON A WALL.

WHEN STACKING, THE UNITS MUST BE STABILIZED USING THE 3/8" MOUNTING HOLES IN THE BACK PANEL, AND BOLTED TOGETHER USING THE 3/8" MOUNTING HOLES IN THE TOP AND BOTTOM PANELS. FASTENERS ARE NOT INCLUDED.

IT IS THE CUSTOMER'S RESPONSIBILITY TO USE ADEQUATE FASTENERS DESIGNED FOR THE SPECIFIC WORKSURFACE, FLOOR, OR WALL TYPE THE UNIT WILL BE ATTACHED TO.

Note: Do not install the 3/8" hole plugs in the top panel if stacking cabinets.

Note: The 3/8" mounting holes located on the back panel are for stabilizing the unit(s) (up to 3 high only) to a wall and are 16" on-center to match most wall construction stud spacing. Figure 2. Be sure fasteners are anchored securely to studs or other solid portion of the wall.

Power drawer setup

1. Open the front door and pull out the power drawer. **Figure 3A.**
2. Mount the 2 power strips to the drawer with Velcro.
Note: The left and right sides of the drawer **Figure 3B** are most commonly used, but the front and back sides **Figure 3C**, or bottom of drawer (not shown) can be used based on the type of chargers and devices that are stored.
3. Route the power strip cords through the drawer and side panel grommet holes and plug into the wall outlet.

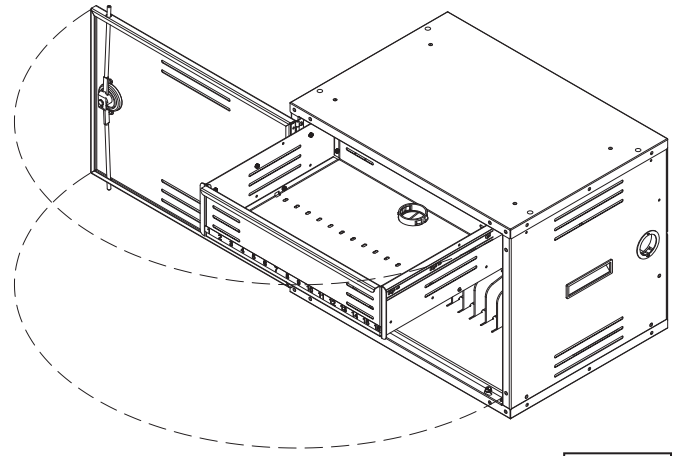

Figure 3A

power strip mounting options

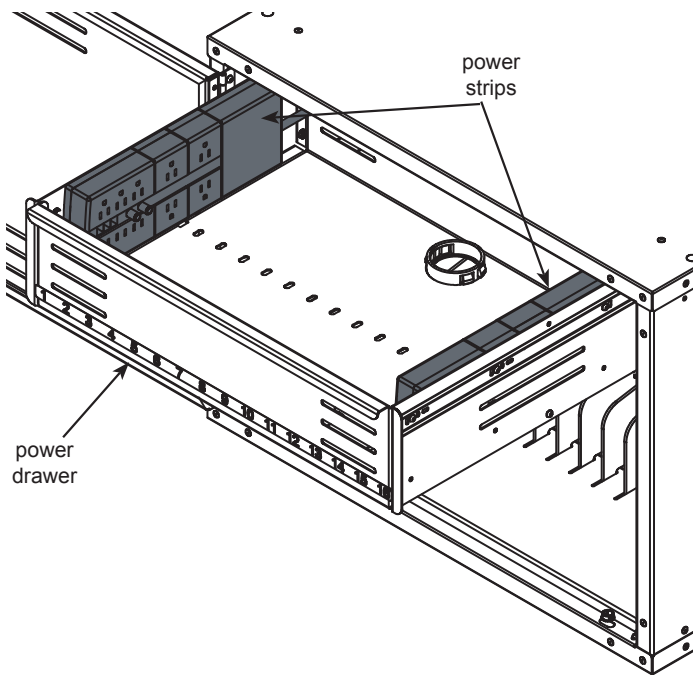

Figure 3B

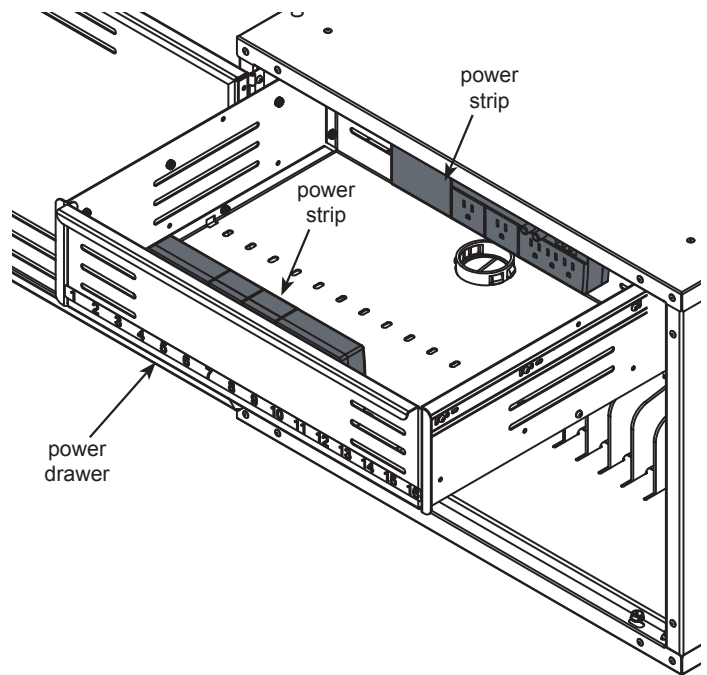

Figure 3C

cord management

1. The cabinet dividers can be configured for use with multiple devices **Figure 4B-C**. If dividers need to be reconfigured, remove the retaining bracket at the back of the cabinet with a Phillips screwdriver, **Figure 4A** remove/reconfigure the dividers, then replace the bracket.

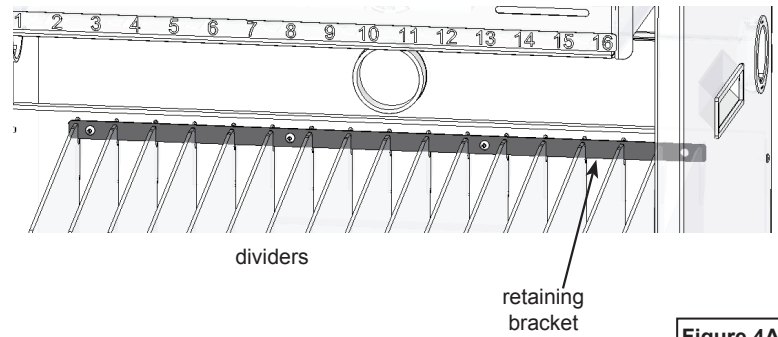

Figure 4A

front view with tablets
(shown without door)

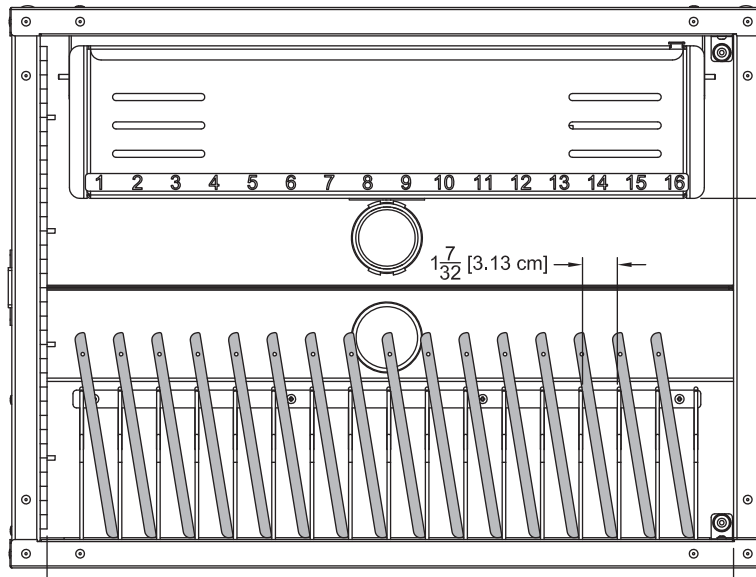

Figure 4B

front view with laptops
(8 dividers removed)
(shown without door)

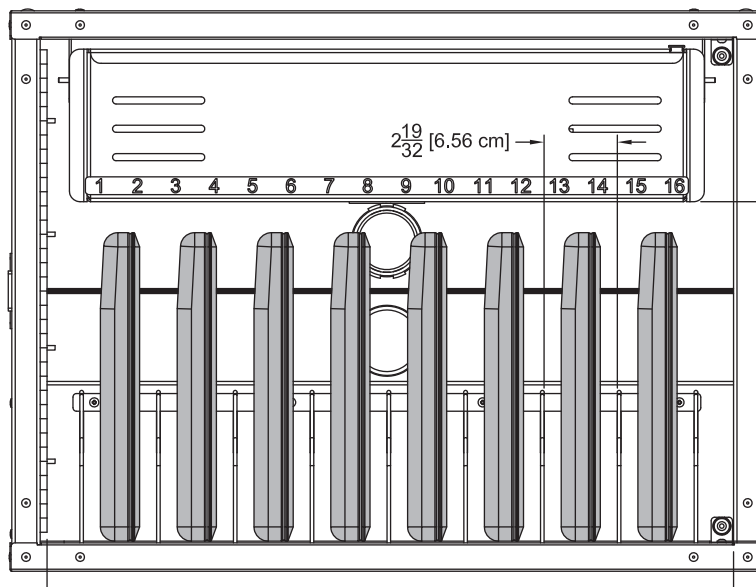

Figure 4C

2. With the power strips unplugged and switched OFF, Plug the chargers into the power strips. Some wall chargers may need to be staggered depending on their size. **Figure 4D-E.**
3. Use the cord wrap cutouts to secure a length of charge cord to each device. **Figure 4F.** Leave just enough slack in the cords to provide easy connection to each device. Long charge cords can be bundled and secured with the chargers and Velcro inside the drawer or behind the devices in the device storage area..

⚠ CAUTION ⚠

Always disconnect the device charge cords before opening the power drawer or damage could occur to the cords or devices.

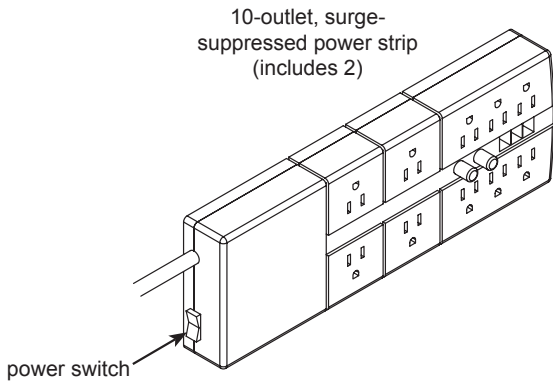

Figure 4D

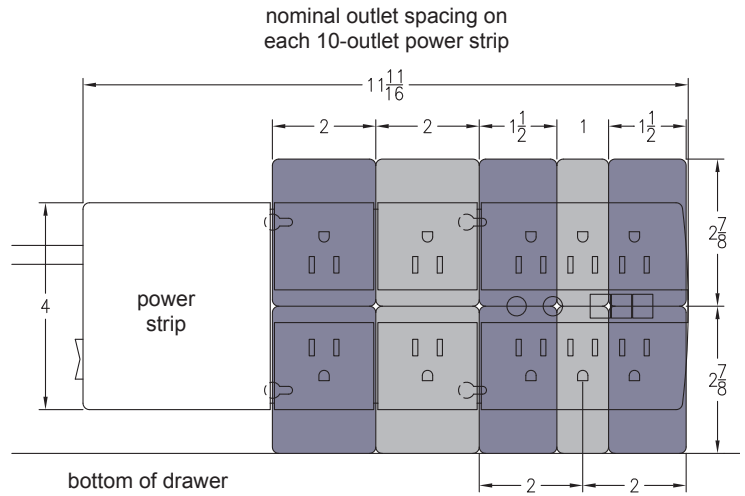

Figure 4E

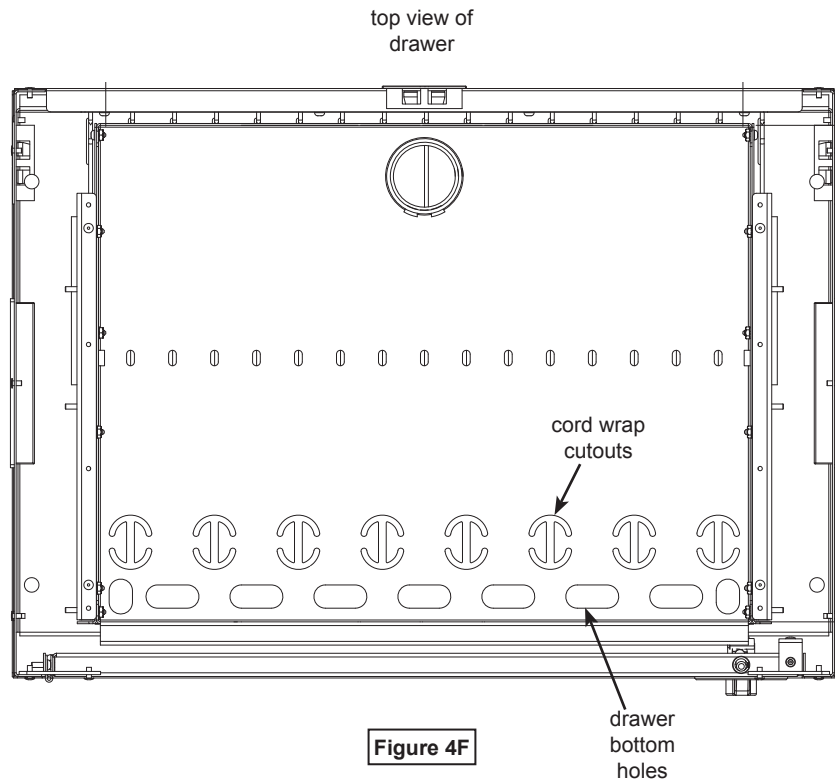

Figure 4F

4. Route the charge cords down through the drawer bottom holes (at front) to the device storage area. **Figure 4G.**
5. Switch the power strips ON and close the drawer.
6. Place the devices into the cabinet. **Figure 4H.**
7. Plug the charge cords into the devices to begin charging.



Figure 4G

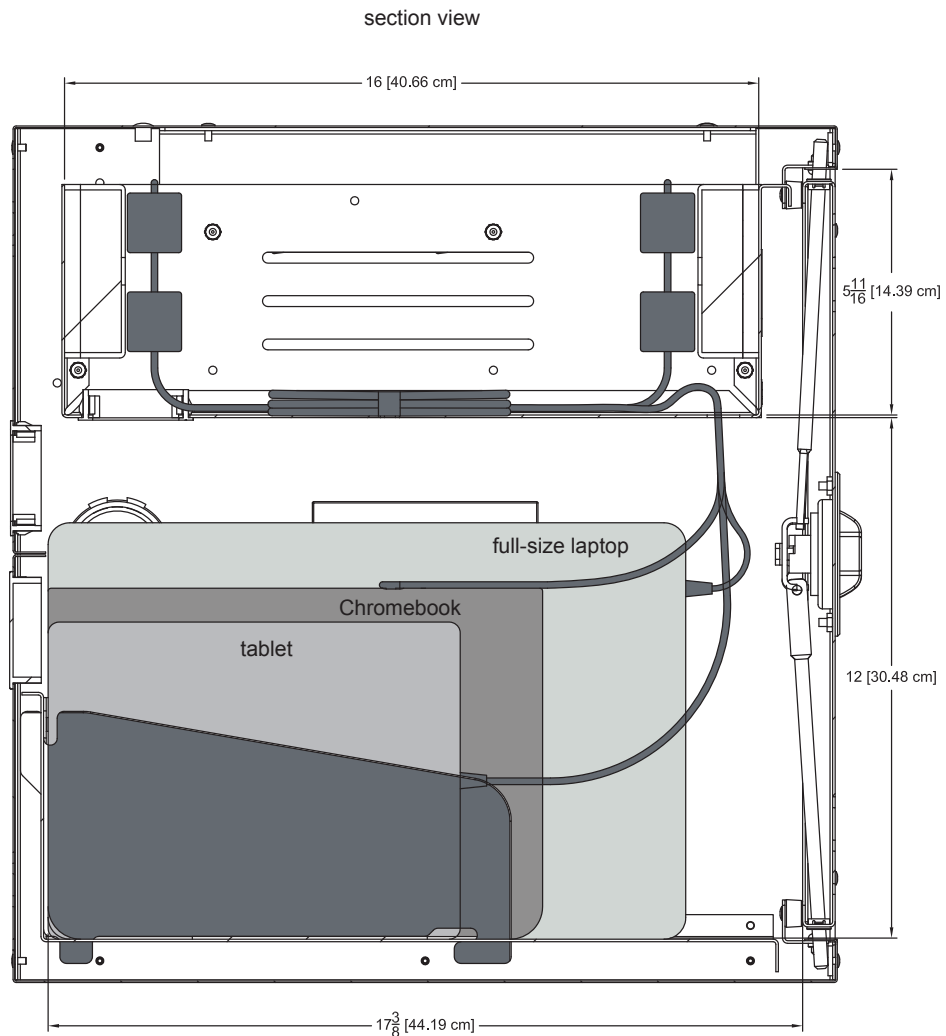
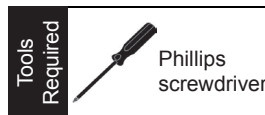

Figure 4H

Changing door swing direction



1. The door can be mounted to be hinged from the left or right-side of the cabinet.
2. To switch the direction, remove the (5) screws that attach the door and hinge to the cabinet.
Figure 5A. Set door and screws aside.
3. Remove the two door stops. **Figure 5B.** Re-attach stops on the opposite side of the cabinet.
4. Flip the door around and attach to the opposite side of the cabinet with the (5) previously removed screws and tighten securely.
5. Close and lock the door. If necessary, the door stops can be adjusted slightly to help align the lock rods with the frame slots.

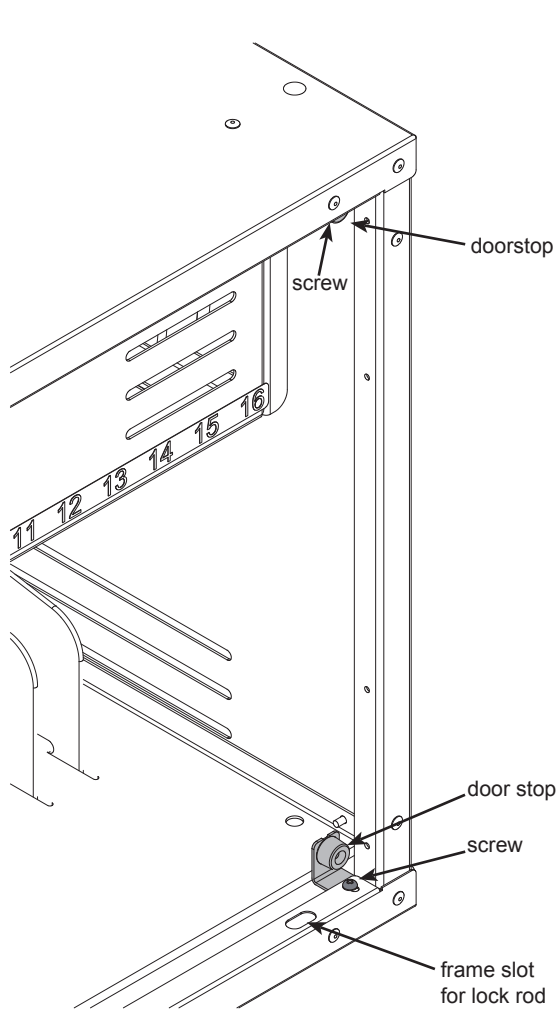

Figure 5B

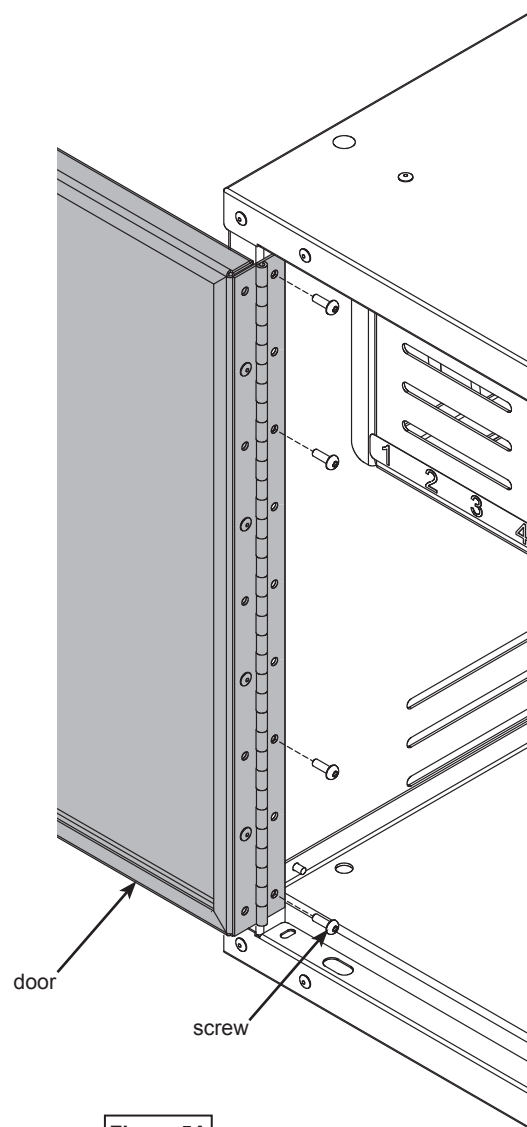

Figure 5A

Door stop adjustment

If necessary, the door stop can be moved to adjust the closed position of the doors and lock rods.

1. To adjust, loosen the Phillips screw slightly with a screwdriver. **Figure 6.**
2. Move the stop until the door is positioned correctly. Be sure the lock rods will engage the lock rod hole.
3. Re-tighten the screw securely.

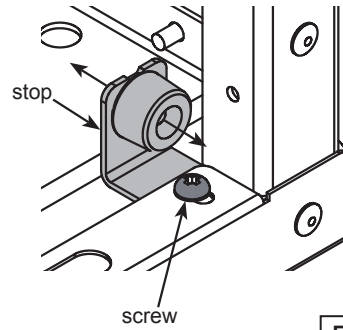
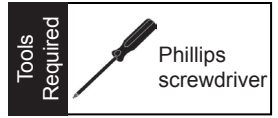

Figure 6

Hole plug installation

1. Install the (4) 3/8" hole plugs into the top of the cabinet. **Figure 7.**
If the units are stacked, install the plugs in the top unit only.

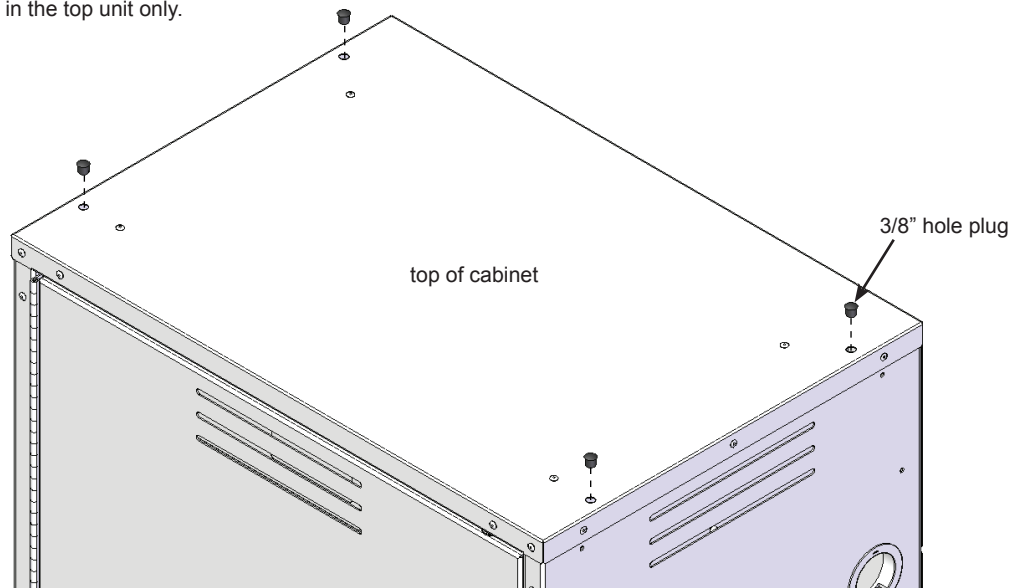

Figure 7

Options



Velcro® strap kit
(16) ¾" x 12", and (32) ¾" x 5"
Velcro® straps
95004



Warranty Statement

WE WILL MAKE IT RIGHT FOR YOU!

Spectrum is committed to provide complete customer satisfaction. Each of our products is manufactured from the best materials available and each product is stringently monitored throughout the production process through our P.A.C.E. program (Product Assurance to meet Customer Expectations).

We expressly warrant that Spectrum products will be of good quality and workmanship and free from defect for the period set out in the warranty table below from the date of delivery. This warranty shall not apply to defects or damage resulting from misuse, abuse, neglect, improper care, modification or repair not authorized by Spectrum, or any other cause outside the control of Spectrum. Spectrum will, at its sole option, either repair or replace the defective product.

This warranty is exclusive; no other warranty, written or oral, is expressed or implied. This warranty is given by Spectrum to Buyer and to no other person or legal entity. No Spectrum dealer, distributor, agent or employee is authorized to make any modification or addition to this warranty.

NOTWITHSTANDING ANYTHING TO THE CONTRARY, SPECTRUM WILL NOT UNDER ANY CIRCUMSTANCES BE LIABLE FOR INDIRECT OR LIQUIDATED DAMAGES, INCLUDING CONSEQUENTIAL, INCIDENTAL AND SPECIAL DAMAGES. IN NO EVENT SHALL SPECTRUM'S LIABILITY, WHETHER UNDER CONTRACT OR WARRANTY, IN TORT OR OTHERWISE, EXCEED THE PURCHASE PRICE RECEIVED BY SPECTRUM FOR THE PRODUCT AT ISSUE AND "RECALL ACTION" EXPENSES. SPECTRUM SHALL NOT BE SUBJECT TO ANY OTHER OBLIGATIONS OR LIABILITIES, WHETHER ARISING OUT OF BREACH OF CONTRACT, WARRANTY, TORT (INCLUDING NEGLIGENCE AND STRICT LIABILITY) OR OTHER THEORIES OF LAW, WITH RESPECT TO PRODUCTS SOLD OR SERVICES RENDERED BY SPECTRUM, OR ANY UNDERTAKINGS, ACTS OR OMISSIONS RELATING THERETO.

Our Customer Service Department is ready to provide immediate attention to any questions, comments or concerns. They are available to answer your calls Monday through Friday from 7 am to 5 pm CST. In addition your product comments or concerns are welcome via e-mail at: spectrum@spectrumfurniture.com.

Warranty Table

Item	Warranty Period
<ul style="list-style-type: none"> • Adjustable Crank/Electric Desk Legs • Flat Panel Desk Gas Cylinders 	<ul style="list-style-type: none"> • 1 Year
<ul style="list-style-type: none"> • Adjustable Height Chair Parts – including frames, gas cylinders, wood and plastic parts, and control handles • Adjustable Height Chair Parts Casters • Adjustable Height Chair Upholstery • In-Stock Upholstery • Graded-In Fabrics and Customer Owned Material 	<ul style="list-style-type: none"> • 7 Years • 2 Years • 2 Years • No Warranty
<ul style="list-style-type: none"> • Height Adjustable Columns and Lifts • General Use Casters • Electrical • Keyboard/Mouse Trays 	<ul style="list-style-type: none"> • 1 Year
<ul style="list-style-type: none"> • Flat Panel Monitor Arm – General Parts • Flat Panel Monitor Arm – Gas Cylinders 	<ul style="list-style-type: none"> • 5 Years • 2 Years
<ul style="list-style-type: none"> • Computer Desk Chassis • Cart Chassis • Lectern Chassis 	<ul style="list-style-type: none"> • 10 Years

